

# **Raspberry Pi**

## **Compute Module 4 IO Board**

An application board for the  
Compute Module 4

# Colophon

© 2020 Raspberry Pi (Trading) Ltd.

The documentation around the Raspberry Pi Compute Module 4 is licensed under a Creative Commons [Attribution-NoDerivatives 4.0 International](#) (CC BY-ND).

build-date: 2021-07-01

build-version: githash: 890200d-clean

## Legal Disclaimer Notice

TECHNICAL AND RELIABILITY DATA FOR RASPBERRY PI PRODUCTS (INCLUDING DATASHEETS) AS MODIFIED FROM TIME TO TIME ("RESOURCES") ARE PROVIDED BY RASPBERRY PI (TRADING) LTD ("RPTL") "AS IS" AND ANY EXPRESS OR IMPLIED WARRANTIES, INCLUDING, BUT NOT LIMITED TO, THE IMPLIED WARRANTIES OF MERCHANTABILITY AND FITNESS FOR A PARTICULAR PURPOSE ARE DISCLAIMED. TO THE MAXIMUM EXTENT PERMITTED BY APPLICABLE LAW IN NO EVENT SHALL RPTL BE LIABLE FOR ANY DIRECT, INDIRECT, INCIDENTAL, SPECIAL, EXEMPLARY, OR CONSEQUENTIAL DAMAGES (INCLUDING, BUT NOT LIMITED TO, PROCUREMENT OF SUBSTITUTE GOODS OR SERVICES; LOSS OF USE, DATA, OR PROFITS; OR BUSINESS INTERRUPTION) HOWEVER CAUSED AND ON ANY THEORY OF LIABILITY, WHETHER IN CONTRACT, STRICT LIABILITY, OR TORT (INCLUDING NEGLIGENCE OR OTHERWISE) ARISING IN ANY WAY OUT OF THE USE OF THE RESOURCES, EVEN IF ADVISED OF THE POSSIBILITY OF SUCH DAMAGE.

RPTL reserves the right to make any enhancements, improvements, corrections or any other modifications to the RESOURCES or any products described in them at any time and without further notice.

The RESOURCES are intended for skilled users with suitable levels of design knowledge. Users are solely responsible for their selection and use of the RESOURCES and any application of the products described in them. User agrees to indemnify and hold RPTL harmless against all liabilities, costs, damages or other losses arising out of their use of the RESOURCES.

RPTL grants users permission to use the RESOURCES solely in conjunction with the Raspberry Pi products. All other use of the RESOURCES is prohibited. No licence is granted to any other RPTL or other third party intellectual property right.

HIGH RISK ACTIVITIES. Raspberry Pi products are not designed, manufactured or intended for use in hazardous environments requiring fail safe performance, such as in the operation of nuclear facilities, aircraft navigation or communication systems, air traffic control, weapons systems or safety-critical applications (including life support systems and other medical devices), in which the failure of the products could lead directly to death, personal injury or severe physical or environmental damage ("High Risk Activities"). RPTL specifically disclaims any express or implied warranty of fitness for High Risk Activities and accepts no liability for use or inclusions of Raspberry Pi products in High Risk Activities.

Raspberry Pi products are provided subject to RPTL's [Standard Terms](#). RPTL's provision of the RESOURCES does not expand or otherwise modify RPTL's [Standard Terms](#) including but not limited to the disclaimers and warranties expressed in them.

# Table of Contents

Colophon .....	1
Legal Disclaimer Notice .....	1
1. Introduction .....	3
2. Features .....	4
2.1. CM4 Module Connectors .....	4
2.2. PSU input .....	4
2.3. Dual Full size HDMI 2.0 connectors .....	4
2.4. Gigabit Ethernet RJ45 .....	5
2.5. USB 2.0 Hub .....	5
2.6. Micro USB connector .....	5
2.7. Micro SD Card socket .....	5
2.8. PCIe Gen 2 x1 socket .....	5
2.9. Fan connector .....	6
2.10. Dual DSI display connectors ( 22pin 0.5mm pitch cable) .....	6
2.11. Dual CSI-2 display connectors ( 22pin 0.5mm pitch cable) .....	6
2.12. A Raspberry Pi HAT connector .....	6
2.13. Real Time Clock (RTC) .....	6
2.14. Jumpers .....	6
2.15. LEDs .....	7
3. Mechanical Diagram .....	8
4. Circuit Diagram .....	9

# Chapter 1. Introduction

Figure 1. Render of the Raspberry Pi Compute Module 4 IO Board.

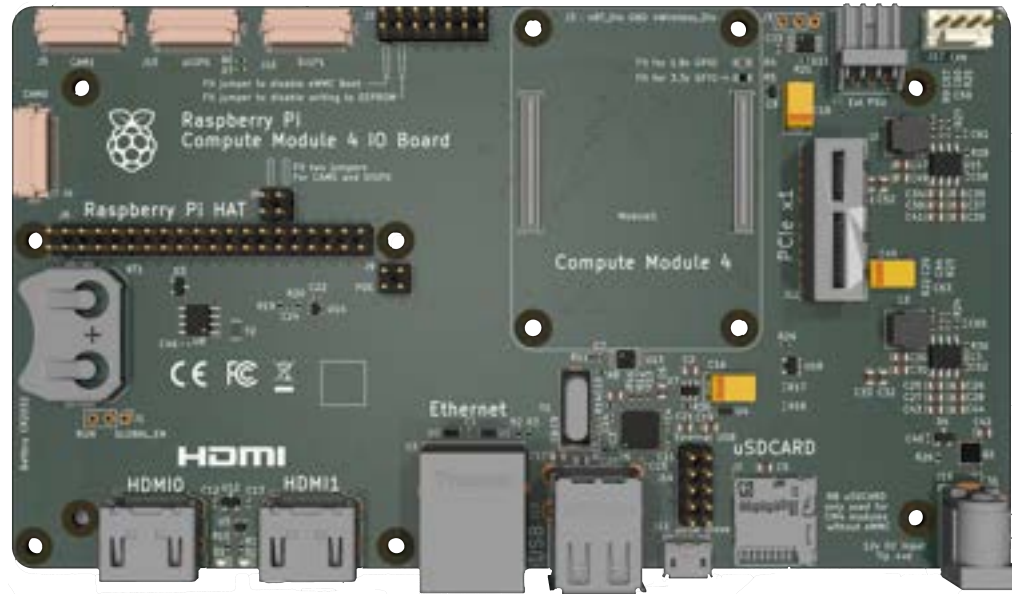

The Raspberry Pi Compute Module 4 IO Board (CM4IO) is designed to assist in the development of products that make use of the Raspberry Pi Compute Module 4. The Raspberry Pi Compute Module 4 IO Board contains many of the interfaces that the Raspberry Pi 4, Model B has, and for general usage you should refer to [Raspberry Pi 4, Model B documentation](#). The significant difference between CM4IO and Raspberry Pi 4, Model B is the addition of a single PCIe socket. The CM4IO has been designed as both a reference design for CM4 or to be used directly as a product with the possible addition of PCIe Cards and Raspberry Pi HATs.

# Chapter 2. Features

- Accepts the complete range of CM4 modules
- External +12V PSU
- 2 × Full-size HDMI 2.0 connectors
- Gigabit Ethernet RJ45 with POE support
- 2 × USB 2 Socket, with header for two more sockets
- Micro USB socket for updating the CM4
- Micro SD Card socket for CM4Lite modules.
- PCIe Gen 2 socket
- Standard Fan connector
- External power connector (+5V, +12V)
- 2 × MIPI DSI display FPC connectors (22pin 0.5mm pitch cable)
- 2 × MIPI CSI-2 camera FPC connectors (22pin 0.5mm pitch cable)
- Raspberry Pi [HAT connector](#)
- RTC with Battery socket and ability to wake up CM4
- Jumpers to disable features, e.g Wireless, EEPROM writing

## 2.1. CM4 Module Connectors

The two CM4 module connectors are positioned so the onboard wireless antenna is at the edge of the board for best wireless performance.

## 2.2. PSU input

The main PSU input (J19) is a 2.1mm DC tip positive +12V input. On board there is a +12V to +5V DC-DC converter to power the CM4. There is also an on-board +12V to +3.3V DC-DC converter PSU which is only used for the PCIe slot. The +12V input feeds the +12V PCIe slot, the external PSU connect and the FAN connector directly. If these aren't being used then a wider input supply is possible ( +7.5V to +28V).

With a +12V supply via the DC barrel jack the external PSU connector ( J20, +5V, +12V ) is ideal to connect to PCIe cards that require external PSU. You should ensure that the PSUs aren't over loaded. J20 Mating connector is known as "Berg" Part number AMP / TE Connectivity 171822-4 or similar.

The exact current required from the +12V PSU is dependent on the application and what is connected to the Raspberry Pi Compute Module 4 IO Board. It is recommended to budget 9W for the CM4.

If you want to supply an external +5v supply to the board e.g. via J20 or via POE J9 then it is recommended that L5 is removed. Removing L5 will prevent the on board +5v and +3.3v supplies from starting up and +5v coming out of the DC JACK socket ( J19 ).

## 2.3. Dual Full size HDMI 2.0 connectors

The CM4 does most of the interfacing required for the HDMI interface so that most signals are directly connected to the CM4. HDMI connectors require a +5V supply, this is provided on the Raspberry Pi Compute Module 4 IO Board via a

current limited switch.

## 2.4. Gigabit Ethernet RJ45

The Raspberry Pi Compute Module 4 IO Board uses a standard 1:1 Ethernet magjack, which supports POE as well. Additional ESD protection is provided on the Raspberry Pi Compute Module 4 IO Board as it is typically needed in POE applications. The POE signals from the RJ45 connector are connected to J5. Typically a POE hat will supply +5v to the Raspberry Pi Compute Module 4 IO Board. As a typically POE HAT doesn't generate a +12v power rail PCIe expansion cards the FAN will not function.

## 2.5. USB 2.0 Hub

The Raspberry Pi Compute Module 4 IO Board has an onboard USB 2.0 hub. This connects to the CM4 USB 2.0 port. Two ports from the hub are connected to a connector. The two other ports are connected to a header, this header can be used to provide two extra internal ports.

There is an internal current limit switch to provide VBUS to the USB connectors. The current limit is set to approximately 1.2A.

The USB interface is disabled to save power by default on the CM4 . To enable it you need to add the following to the config.txt file :

```
dtoverlay=dwc2,dr_mode=host
```

## 2.6. Micro USB connector

The micro USB connector is designed to enable the CM4 to be updated via rpiboot. When a micro USB cable is plugged in the USB hub is automatically disabled, so the CM4 USB 2.0 port becomes a USB device.

## 2.7. Micro SD Card socket

### ⊖ WARNING

For use only with CM4Lite modules

The micro SD Card socket is a PUSH-PUSH socket. To release the micro SD Card a gentle push on the micro SD Card will enable it to be removed.

## 2.8. PCIe Gen 2 x1 socket

The PCIe socket is designed to take standard PC PCIe cards. You should ensure that there is a suitable OS driver for your card.

The PCIe link on the Raspberry Pi 4, Model B is used for the USB 3.0 interface via the VLI805 XHCI controller. If the application requires USB 3.0 interface then an external XHCI controller is required like the VLI805.

The PCIe link has been successfully used with an NVMe drive via a passive PCIe adaptor. Currently the CM4 bootloader doesn't support NVMe drives so you must boot via a different source.

If the application uses a standard PCIe card then it might be useful to have a small PCIe adaptor to rotate the PCIe card 90degrees to enable a more compact case.

Note the PCIe Interface doesn't support MSI-X. Typically PCIe devices will fall back to MSI.

## 2.9. Fan connector

This connector supports standard +12V FANs with PWM drive and tacho output. An EMC2301 controls the fan via I2C. Mating connector part number Molex 47054-1000 or similar. The +12V power for the fan comes from the +12V input and isn't regulated.

### TIP

To enable the I2C bus to the fan controller you will need `dtparam=i2c_vc=on` set in config.txt . The fan controller then will be on i2c-10 address 0x2f ( 7bit address)

## 2.10. Dual DSI display connectors ( 22pin 0.5mm pitch cable)

Both DSI interfaces ( 2 channel and 4 channel) are brought out to separate 22way 0.5mm pitch connectors. These connectors are the same as on the existing CMIO board, NB they are different from the Raspberry Pi 4, Model B. If the DSI0 interface ( 2 channel ) is used then the 2 jumpers on J6 must be fitted to route the I2C bus to the connector

## 2.11. Dual CSI-2 display connectors ( 22pin 0.5mm pitch cable)

Both CSI-2 interfaces ( 2 channel and 4 channel) are brought out to separate 22way 0.5mm pitch connectors. These connectors are the same as on the existing CMIO board, NB they are different from the Raspberry Pi 4, Model B. If the CSI0 interface ( 2 channel ) is used then the 2 jumpers on J6 must be fitted to route the I2C bus to the connector

## 2.12. A Raspberry Pi HAT connector

The Raspberry Pi Compute Module 4 IO Board has a standard Raspberry Pi 40 way HAT connector. The mounting holes are also provided so that standard HATs may be used.

## 2.13. Real Time Clock (RTC)

A PCF85063AT RTC is provided on the Raspberry Pi Compute Module 4 IO Board. A battery socket is provided for a CR2032 battery. On initial setup the CLKOUT of the RTC should be disabled to save power.

The alarm output of the RTC is used to wakeup the CM4 from a previous shutdown. If an alarm goes off during normal operation the CM4 will be reset, this can be used as a watchdog timer if required.

### TIP

To enable the I2C bus to the RTC you will need `dtparam=i2c_vc=on` set in config.txt . The RTC then will be on i2c-10 address 0x51 ( 7bit address)

## 2.14. Jumpers

### *R4/R5 Vref Voltage Selection*

By default the Raspberry Pi Compute Module 4 IO Board sets the CM4 IO voltage to +3.3v via R5. Moving R5 to R4 sets the IO voltage on the CM4 to +1.8v . Moving the resistor requires the use of the soldering iron.

**NOTE**

Only one of R4 or R5 must be fitted at any one time.

**NOTE***J6 CSIO DSI0 I2C enable*

For the J6 jumpers, if either CSIO or DSI0 is used then both jumpers must be fitted to route the I2C bus to the connectors

Table 1. J2 jumpers

Pin	Function
1-2	nRPIBOOT If fitted forces USB booting, it is useful if the eMMC becomes corrupted.
3-4	EEPROM_nWP If fitted write protects the EEPROM on the CM4
5	AIN0 MXL7704 analog input consult MXL7704 datasheet for details
6	AIN1 MXL7704 analog input consult MXL7704 datasheet for details
7	GND for AIN signals
8	SYNC_IN
9	SYNC_OUT
10	GND
11	TV_OUT
12	GND
13-14	Connect a push button to wake up the CM4 from low power mode. It can't be used to shutdown the CM4.

Table 2. J3 (not fitted by default)

Pin	Function
1	WL_nDIS when connected to ground the wireless interface will be disabled
2	GND Ground
3	BT_nDIS when connected to ground the Bluetooth interface will be disabled

Table 3. J1 (not fitted by default)

Pin	Function
1	GLOBAL_EN
2	GND
3	RUN_PG

## 2.15. LEDs

### Red LED

This LED duplicates the function of the RED LED on the Raspberry Pi 4, Model B

### Green LED

This LED duplicates the function of the GREEN LED on the Raspberry Pi 4, Model B



# Chapter 3. Mechanical Diagram

Figure 2. Mechanical diagram of the Raspberry Pi Compute Module 4 IO Board.

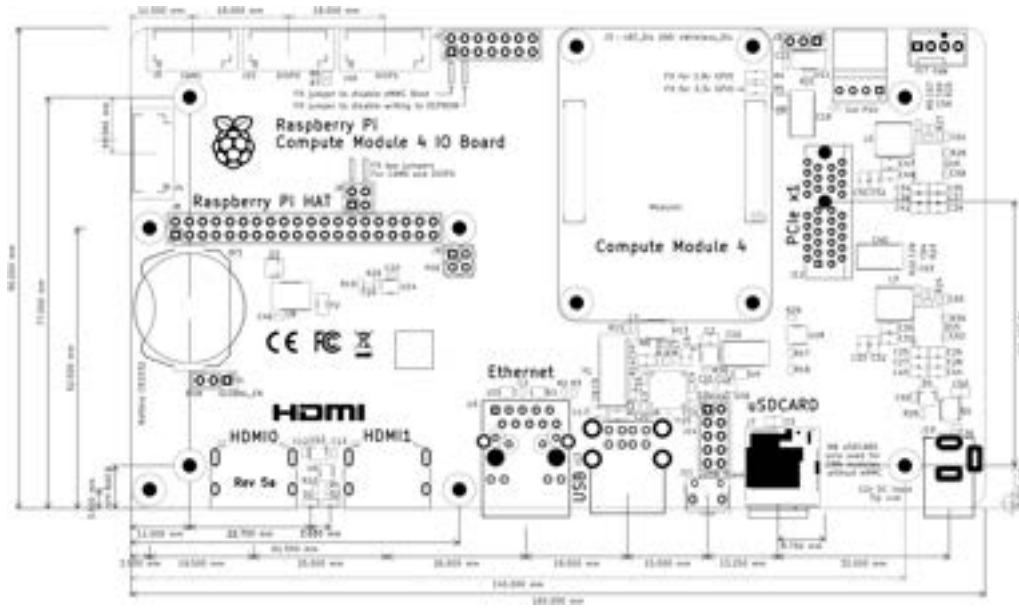

# Chapter 4. Circuit Diagram

Figure 3. Top level

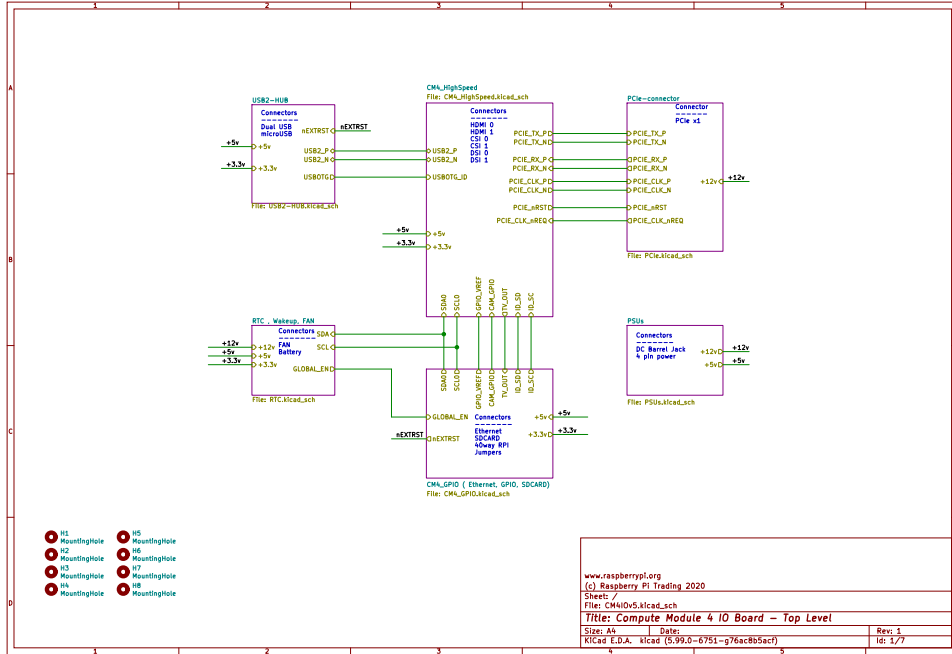

Figure 4. CM4 Highspeed

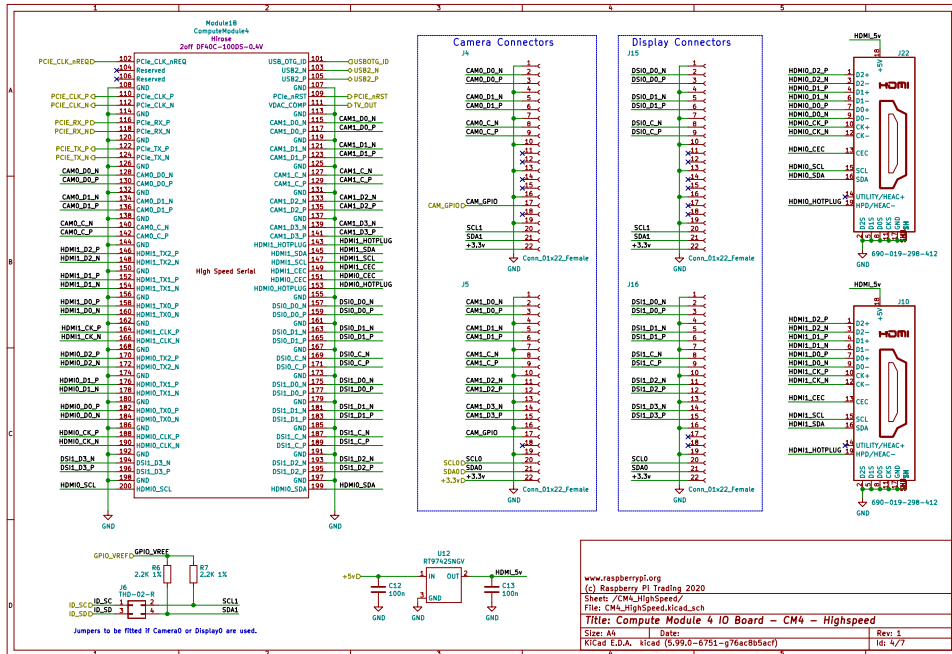

Figure 5. CM4 GPIO

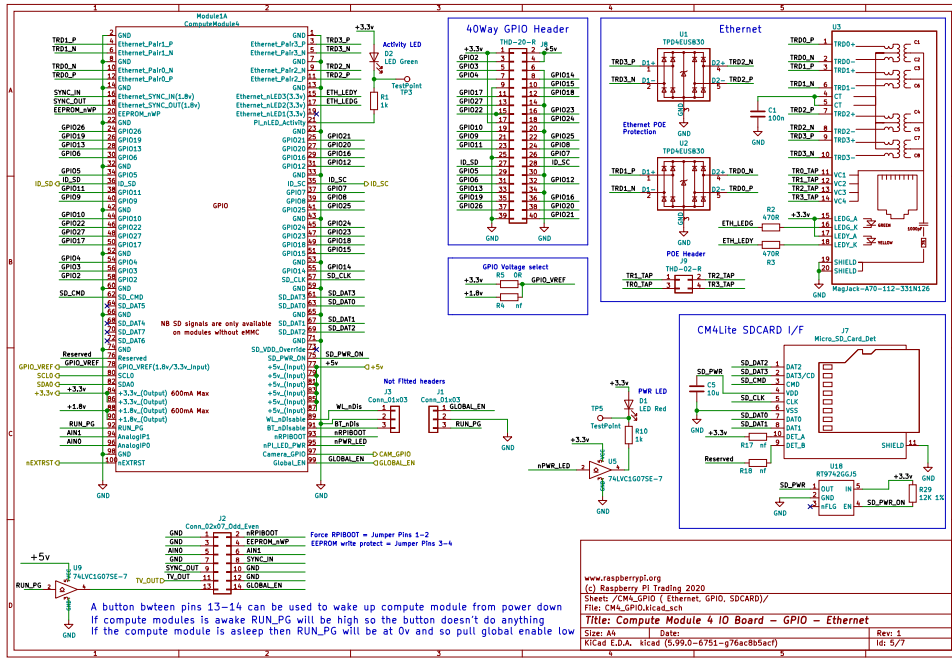

Figure 6. PCIe Connector

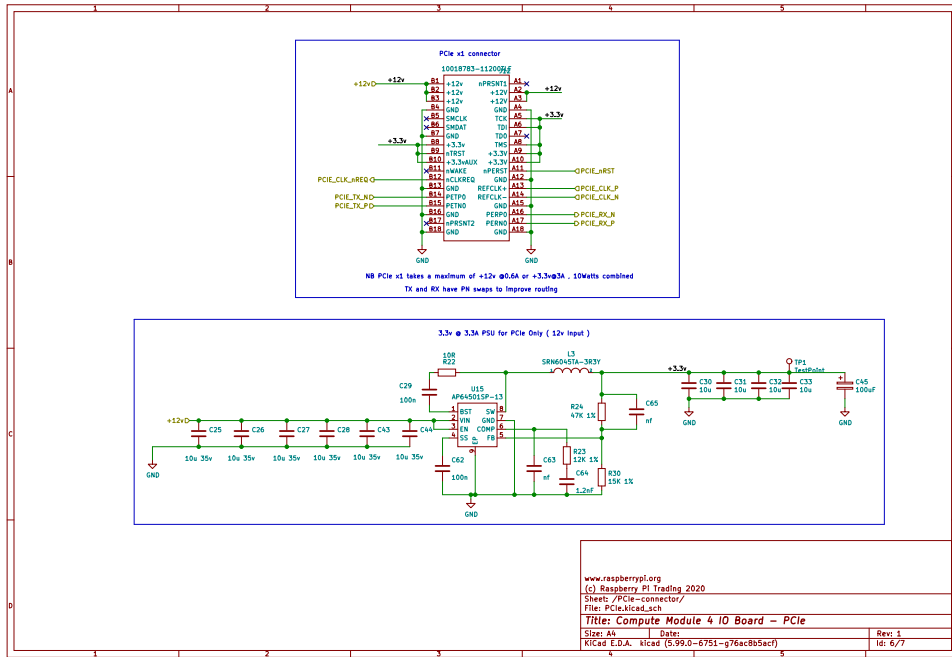

Figure 7. USB2 Hub

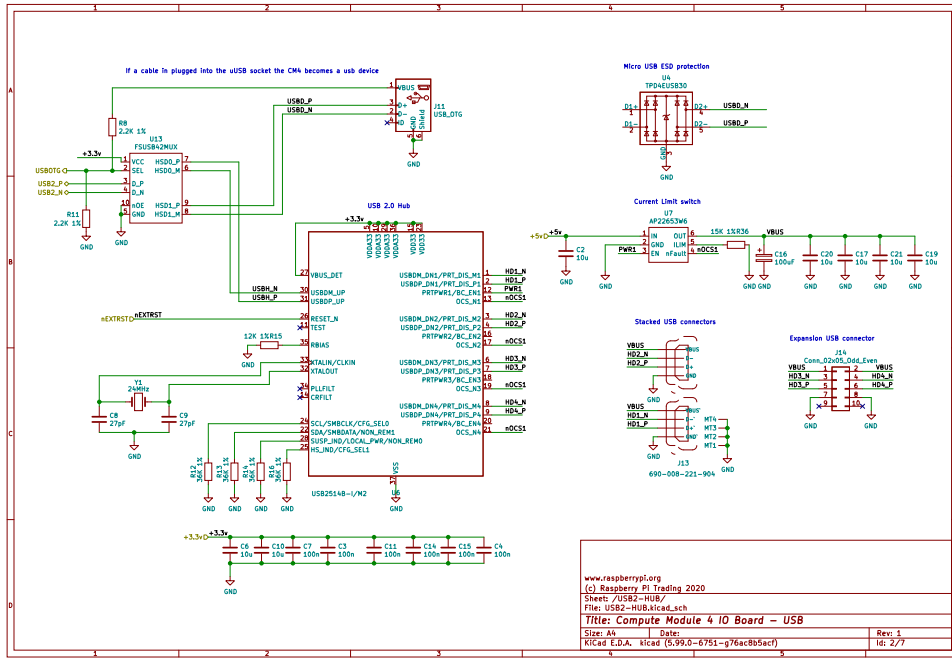

Figure 8. RTC Wakeup FAN

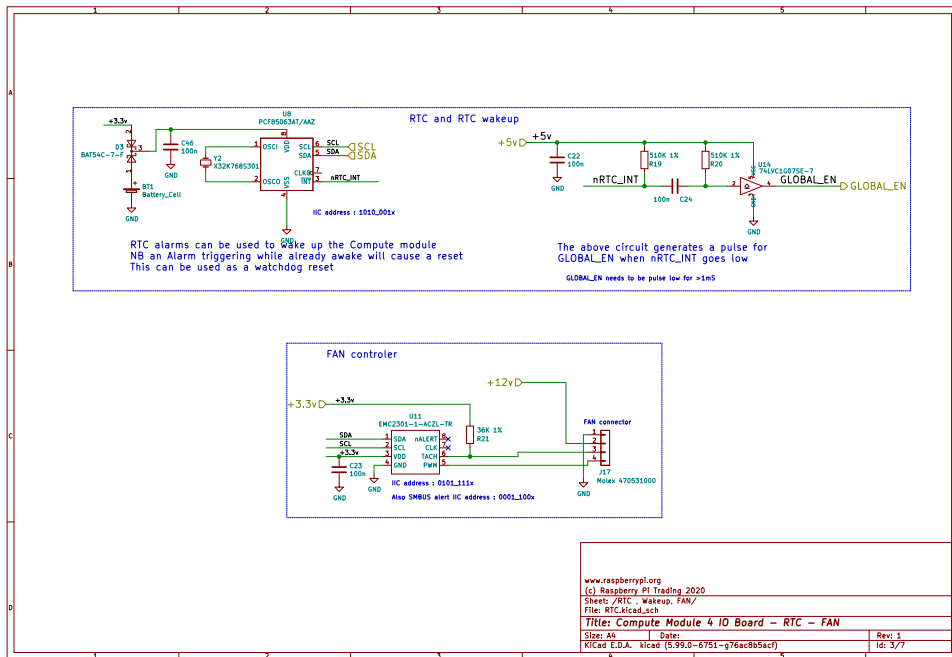
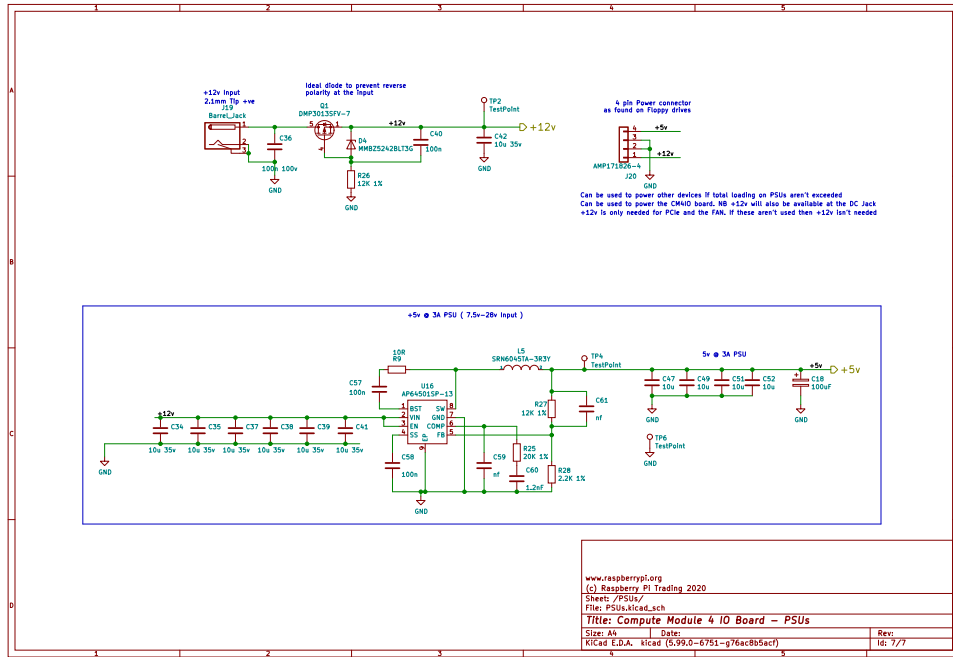

Figure 9. PSU





**Raspberry Pi**

Raspberry Pi is a trademark of the Raspberry Pi Foundation

---

**Raspberry Pi Trading Ltd**